

Application Information

RIGGING PRACTICE SHACKLES

Screw pin shall be fully engaged. If designed for a cotter pin, it shall be used and maintained. Applied load should be centered in the bow to prevent side loading. Multiple sling legs should not be applied to the pin. If side loaded, the rated load shall be reduced according to Table 1 on the following page.

Screw Pin Shackles Pin Security



MOUSE SCREW PIN WHEN USED IN LONG-TERM OR HIGH-VIBRATION APPLICATIONS. Mouse or Mousing (screw pin shackle) is a secondary securement method used to secure screw pin from rotation or loosening. Annealed iron wire is looped through hole in collar of shackle body and around adjacent leg of shackle body with wire ends securely twisted together.

Shackles



ROUND PIN
Do not side load, do not use as a collector ring, always use cotter pin.



SCREW PIN
Use when picking and placing a load, tighten pin prior to each lift.

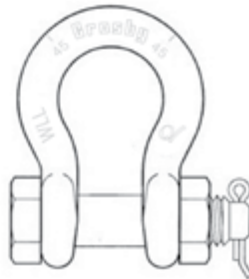

BOLT-TYPE
Use in permanent or long-term installations, always use nut and cotter.

Connection of Slings to Shackles



Diameter of shackle must be greater than wire rope diameter if no thimble in eye.



Shackle must be large enough to avoid pinching of synthetic slings.

Note that the effective width of the curved surface is only 75% of width.

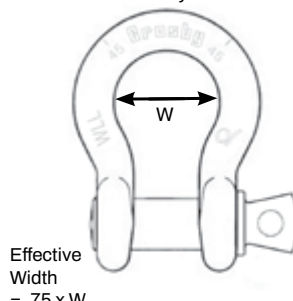

Effective Width = .75 x W

Bolt-Type Shackles

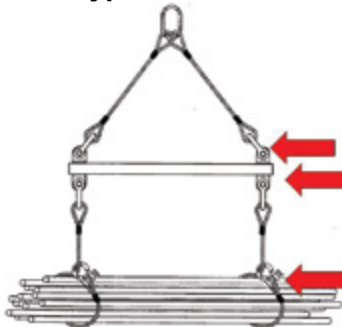

Use Bolt-Type Shackle for permanent or long-term connection.

Use Screw Pin Shackle for temporary connection.

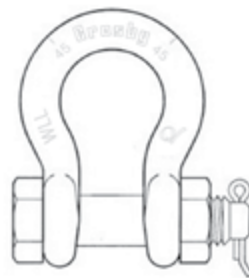

Not necessary to tighten nut. Always use cotter pin.

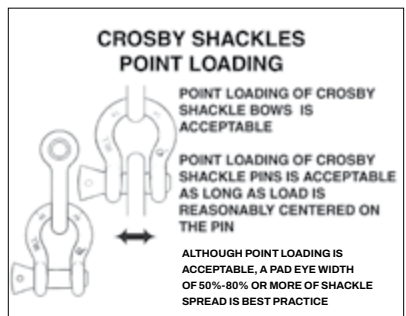
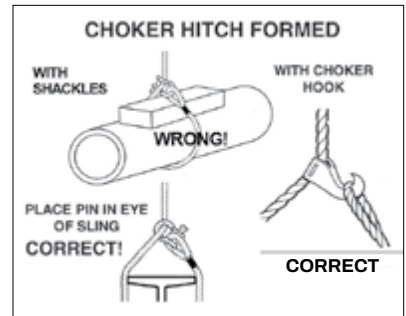
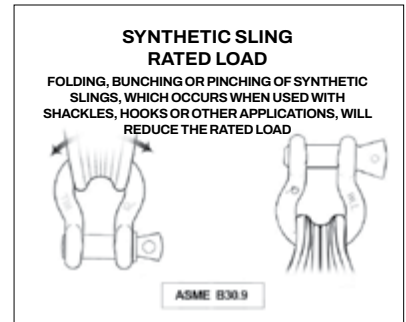
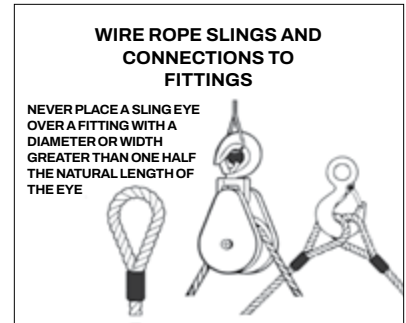
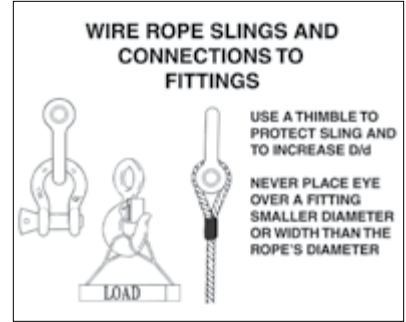

Installation Guidelines

1. Extended prong cotter pins should be inserted into hole until the head is tangent to the bolt/pin, and oriented so the axis of the eye is parallel to the shank of the bolt/pin.
2. The prongs are to be bent in opposite directions around the bolt or pin as shown in Figure 1 below.
3. After installation, the cotter pin prongs should wrap around the bolt or pin by at least 60 degrees opposite directions of bolt or pin diameter.
4. The prongs may be bent with pliers or by gently tapping with a hammer. *Note: Avoid bending the prongs over sharp radii which may promote breakage. If a prong breaks off or becomes damaged during installation, replace the cotter pin.
5. The ends of the prongs may be curled to form a small loop to reduce the potential for snagging or puncture wounds.

Cotter Pin Sizes For Crosby Shackles

213 & 215 SHACKLES	
SHACKLE SIZE	COTTER PIN SIZE
1/4"	3/32 x 3/4"
5/16"	3/32 x 1"
3/8"	1/8 x 1"
7/16"	1/8 x 1"
1/2"	1/8 x 1"
5/8"	3/16 x 1 1/4"
3/4"	3/16 x 1 1/4"
7/8"	5/16 x 1 1/2"
1"	5/16 x 1 3/4"
1 1/8"	5/16 x 1 3/4"
1 1/4"	5/16 x 2"
1 3/8"	5/16" x 2 1/4"
1 1/2"	5/16" x 2 1/4"
1 3/4"	5/16" x 2 3/4"
2"	3/8 x 3"

2130 & 2150 SHACKLES	
SHACKLE SIZE	COTTER PIN SIZE
3/16"	3/32 x 3/4"
1/4"	3/32 x 3/4"
5/16"	3/32 x 1"
3/8"	1/8 x 1"
7/16"	1/8 x 1"
1/2"	1/8 x 1"
5/8"	3/16 x 1 1/4"
3/4"	3/16 x 1 1/4"
7/8"	1/4 x 1 1/2"
1"	1/4 x 1 3/4"
1 1/8"	1/4 x 1 3/4"
1 1/4"	1/4 x 2"
1 3/8"	5/16 x 2 1/4"
1 1/2"	5/16 x 2 1/4"
1 3/4"	5/16 x 2 3/4"
2"	3/8 x 3"
2 1/2"	7/16 x 4"
3"	3/8 x 4 1/2"
3 1/2"	3/8 x 4 1/2"
4"	3/8 x 4 1/2"

2140 SHACKLES	
SHACKLE SIZE	COTTER PIN SIZE
1 1/2"	5/16" x 2 1/4"
1 3/4"	5/16" x 2 3/4"
2"	3/8" x 3"
2 1/2"	7/16" x 4"
3"	3/8" x 4 1/2"
3 1/2"	3/8" x 4 1/2"
4"	3/8" x 4 1/2"
4 3/4"	3/8" x 7"
5"	3/8" x 8"
6"	3/8" x 8 1/2"
7"	3/8" x 10 1/2"
7 1/2"	3/8" x 10 1/2"
8"	3/8" x 13 1/2"

2160 SHACKLES	
SHACKLE WLL (t)	COTTER PIN SIZE
7	3/16" x 1 1/4"
12-1/2	1/4" x 1 3/4"
18	1/4" x 2"
30	5/16 x 2 1/4"
40	5/16" x 2 3/4"
55	3/8" x 3"
75	3/8" x 3"
125	3/8" x 4"
200	1/2" x 5 1/4"
300	5/8" x 6"
400	5/8" x 8"
500	3/4" x 9"
600	3/4" x 10"
700	3/4" x 11"
800	3/4 x 13" R3
900	3/4" x 13"
1000	3/4" x 14"
1250	3/4" x 15"
1500R3	3/4" x 17"
2000	5/8" x 18 3/4"
4"	3/8 x 4 1/2"

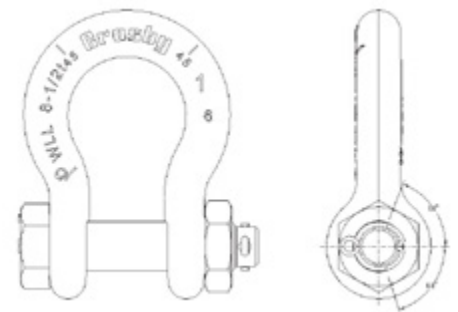

Figure 1
Cotter pin installation in a 1" bolt type shackle.

Application Information

Point Loading of Crosby® Shackles

It has been determined that all Crosby shackles can be point-to-point loaded to the Working Load Limit without bending of the pin/bolt. This loading can be bow-to-bow, bow-to-pin, or pin-to-pin (if there is not interference between the diameter of the shackle ears). However, caution should be given to maintain the load at the center of the span by spacers so the load will not slide over to one side, and overload that ear. See “Off Center Loading Of Crosby® Screw Pin & Bolt Type Shackles – 3/16” to 3” Sizes”.

Angular Loading Of Crosby® Screw Pin & Bolt Type Shackles

Crosby has made representative tests with smaller size shackles with the load applied at 90 degrees to the normal plane of loading (ie. in-line). The test results indicated that in order to maintain a proof load of 2 times the Working Load Limit (2 x WLL), the Working Load Limit should be reduced to 50% (ie. one-half the catalog working load rating). **DO NOT SIDE LOAD G/S-213 OR G/S-215 ROUND PIN SHACKLES.** Calculations based on the above test indicates the Working Load Limit should be reduced as shown below for loads applied at various angles to the normal plane of loading:

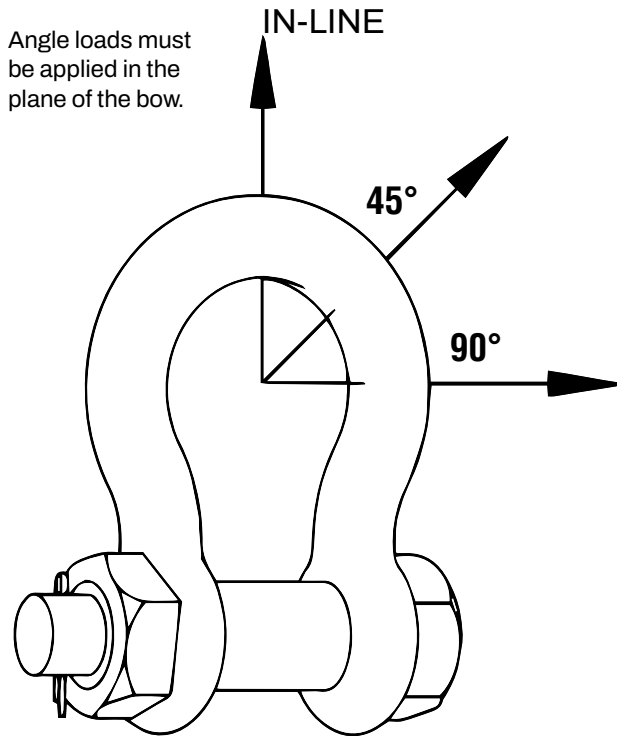

SIDE LOADED RATING REDUCTION TABLE FOR 3/16” - 3” (120 METRIC TONS)

Table 1	
Side Loading Reduction Chart for Screw Pin and Bolt Type Shackles Only+	
Angle of Side Load from Vertical In-Line of Shackle	Adjusted Working Load Limit
0° - 10° In-Line*	100% of Rated Working Load Limit
11° - 20° from In-Line*	85% of Rated Working Load Limit
21° - 30° from In-Line*	75% of Rated Working Load Limit
31° - 45° from In-Line*	70% of Rated Working Load Limit
46° - 55° from In-Line*	60% of Rated Working Load Limit
56° - 70° from In-Line*	55% of Rated Working Load Limit
71° - 90° from In-Line*	50% of Rated Working Load Limit

+ In-Line load is applied perpendicular to pin. * DO NOT SIDE LOAD ROUND PIN SHACKLE.

Table 1	
SHACKLE SIZE GREATER THAN 3” ANGLE FROM IN-LINE (DEGREES) REDUCTION IN WLL	
0° - 5° In-Line*	0% of Rated Working Load Limit
6° - 10° from In-Line*	15% of Rated Working Load Limit
>10° from In-Line*	ANALYSIS REQ'D.

For shackles larger than 125 metric tons, where the angle of the side load is greater than 5 degrees, contact Crosby Engineering.

INCLUDED ANGLE - SHACKLES

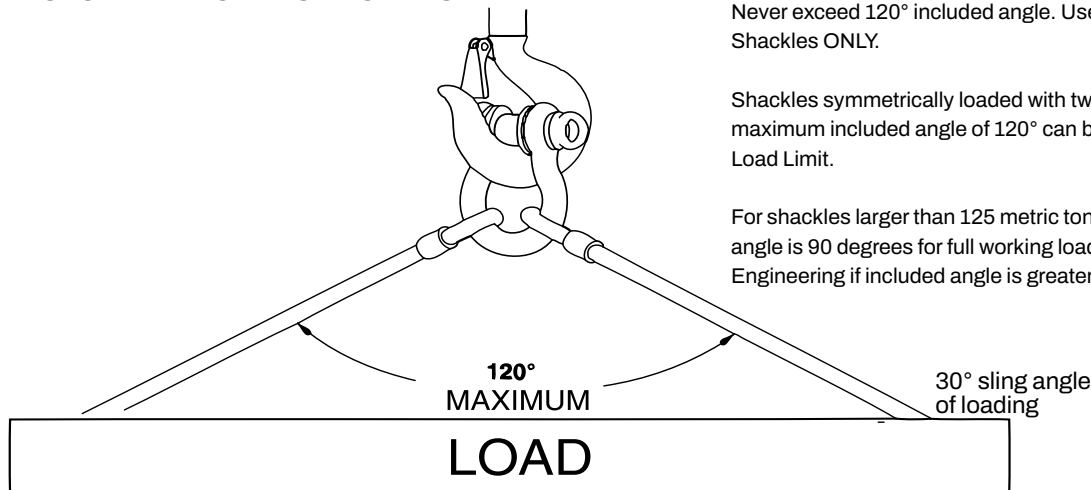

Never exceed 120° included angle. Use Bolt Type and Screw Pin Shackles ONLY.

Shackles symmetrically loaded with two leg slings having a maximum included angle of 120° can be utilized to full Working Load Limit.

For shackles larger than 125 metric tons, the maximum included angle is 90 degrees for full working load limit. Contact Crosby Engineering if included angle is greater than 90 degrees.

For shackles larger than 125 metric tons, the maximum included angle is 90 degrees for full working load limit. Contact Crosby Engineering if included angle is greater than 90 degrees.

Application Information

Round Pin Shackles



Round Pin Shackles can be used in tie down, towing, suspension or lifting applications where the load is strictly applied in-line. Round pin shackles should never be used in rigging applications to gather multiple sling legs, or where side loading conditions may occur.

Bolt-Type Shackles



Bolt-Type Shackles can be used in any application where round pin or screw pin shackles are used. In addition, they are recommended for permanent or long term installations and where the load may slide on the shackle pin causing the pin to rotate. The bolt-type shackle's secondary securement system, utilizing a nut and cotter, eliminates the requirement to tighten nut before each lift or movement of load.

Screw Pin Shackles



Screw Pin Shackles are used in Pick and Place* applications. For permanent or long-term installations, Crosby recommends the use of bolt type shackles.

If you choose to disregard Crosby's recommendation, the screw pin shall be secured from rotation or loosening .

Screw pin shackles can be used for applications involving side-loading circumstances. Reduced working load limits are required for side-loading applications. While in service, do not allow the screw pin to be rotated by a live line, such as a choker application.

* Pick and Place application: Pick (move) a load and place as required. Tighten screw pin before each pick.

QUIC-CHECK®



All Crosby Shackles, with the exception of 2160, 2169, 2170, 252 and 253 styles incorporate markings forged into the product that address an easy to use QUIC-CHECK® feature. Angle indicators are forged into the shackle bow at 45 degree** angles from vertical. These are utilized on screw pin and bolt type shackles to quickly check the approximate angle of a two-legged hitch, or quickly check the angle of a single leg hitch when the shackle pin is secured and the pull of the load is off vertical (side loaded), thus requiring a reduction in the working load limit of the shackle.

** Round Pin Shackles utilize the 45 degree QUIC-CHECK® indicators to ensure load is applied strictly in-line.

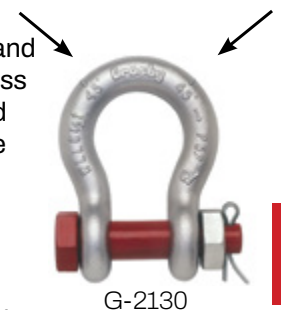

Technical Information

2006/42/EC highlights the responsibility of the manufacturer, distributor and end user of lifting gear. Gunnebo Industries shackles are specified, monitored and documented in compliance with the most stringent requirements for the product concerned. A certified ISO 9001:2008 to 9001:2015 system is an evidence of our quality standard. See website or user instructions for assembly instructions. Meets listed current specifications and standards at time of publication of this catalog.

Instructions For Safe Use

1. The user is obliged to keep a valid Test Certificate for any shackle being used in a lifting operation.
2. Before use each shackle should be inspected to ensure that:
 - all markings in the body and the pin of the shackle are legible and in compliance with the relevant Test Certificate.
 - the shackle pin is of the correct type.
 - the body and pin are not distorted or unduly worn.
 - The body and pin are free from nicks, cracks, grooves and corrosion.
 - If there is any doubt with regards to the above criteria being met, the shackle should not be used for a lifting operation.
3. It is important to ensure that the pin is safely locked after assembly. For repeated lifting between inspections of the gear, it is recommended to use a safety bolt type shackle with nut and split-pin - the user must ensure that the split-pin is fitted, to prevent the nut from unscrewing during use.
4. Incorrect seating of a pin may be due to a bent pin, damaged threads or misalignment of the holes. Do not use the shackle under these circumstances, but refer the matter to a competent person (i.e. dealer, manufacturer)
5. Shackles should be fitted to the load in a manner that allows the shackle body to take the load in a straight line along its centerline to avoid undue bending stresses which will reduce the load capacity of the shackle. When using shackles in conjunction with multi-leg slings, due consideration should be given to the effect of the angle between the sling legs. When a shackle is used to secure the top block of a set of block and tackle the load on this shackle is increased by the value of the hoisting effect.
6. To avoid eccentric loading of the shackle it is recommended to center load on pin as far as possible over the total length of the pin or to use loose spacers.
7. Never modify, repair or reshape a shackle by welding, heating or bending as this will affect the nominal WLL.
8. Never heat treat a shackle as this may affect the WLL.

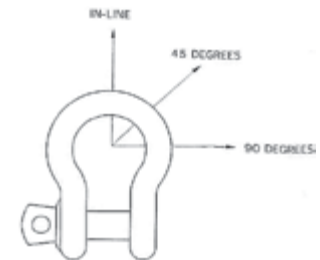

Side loads should be avoided as the products are not designed for this purpose. If side loads cannot be avoided, the following reduction factors must be taken into account:

Reduction for side loading

Load angle	New Working Load Limit
0°	100% of original WLL
45°	70% of original WLL
90°	50% of original WLL

Avoid applications where, due to load movement, the shackle pin can rotate

Shackle must be loaded in straight direction

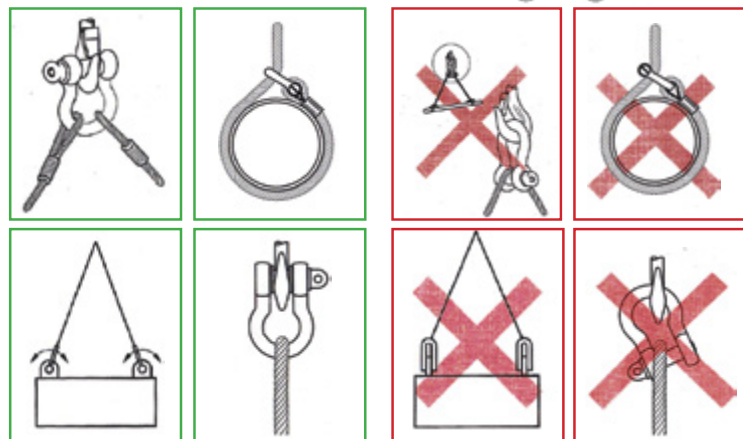

Temperature

If extreme temperature situations are applicable, the following load reductions must be taken into account.

Reduction for elevated temperatures

Temperature:	New Working Load Limit
-20 - 200° C	100% of original Working Load Limit
200 - 300° C	90% of original Working Load Limit
300 - 400° C	75% of original Working Load Limit
> 400° C	not allowed