

ROV Eye Shank Hook Crosby L-562A

Product information



Features:

- QUIC-CHECK® angle indicators forged into the top eye; and deformation and angle indicators forged on the hook.
- Tip extension allows for easy handling.
- Sizes 5.4t through 31.5t utilize new integrated latch (S-4320) that meets the worldclass standard for lifting.
- Heavy duty stamped latch interlocks with the hook tip.
- High cycle, long life spring.
- Pad eyes are provided on either side of hook as cable guides. The cable is passed through a hole drilled in the latch that assists in allowing the “remotely operated” cable to open latch.
- Cables and drilled latches are not provided by Crosby. They can be fitted by your local Authorized Crosby Dealer.

... [Read more](#)

Material: Alloy steel - Quenched and Tempered.

Marking: Code

Finish: Painted with fluorescent yellow for high subsea visibility

Safety factor: 4:1

Grade: 8

ROV Eye Shank Hook Crosby L-562A

Blueprint

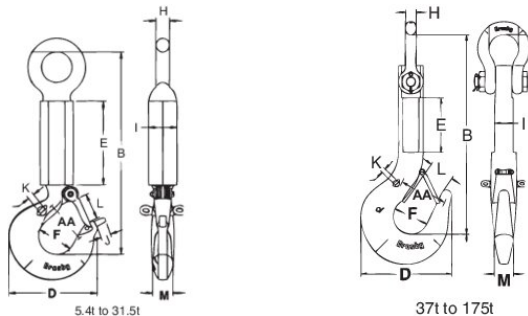

Technical data

Part code	WLL ton	Hook ID Code	B mm	D mm	E mm	F mm	H mm	I mm	K mm	L mm	M mm	AA**mm mm	J mm	Weight kg
420500540520	5.4	IA	421	123	250	51	22	65	6.4	35	29	63.5	9.9	9.5
420501150520	11.5	KA	518	192	250	76	32	65	9.7	53	41	330	30	15
420501600520	16	LA	550	212	250	83	35	65	9.7	58	49	330	30	18
420502200520	22	NA	608	263	250	108	40	85	19	77	60	305	45	31
420503150520	31.5	OA	660	346	250	127	48	85	19	106	76	254	-	44
420503700520	37	PA	828	357	235	137	47	80	19	95	76	203	-	44
420504500520	45	SA	865	392	235	152	47	80	19	108	83	177	-	90
420506000520	60	TA	941	470	215	178	53	90	19	130	99	165	-	131
420510000520	100	WA	1,185	584	300	173	69	140	19	124	140	127	-	303
420515000520	150	XA	1,233	619	230	171	92	150	19	137	152	101	-	395
420517500520	175	YA	1,326	678	255	191	102	170	19	-	178	101	-	515