

Vertical Lifting Clamp IPU10J

Product information



The IPU10J vertical lifting clamp with larger jaw opening is used for lifting, turning, moving or vertical transfer of sheet, plates, or fabrications from horizontal to vertical and down to horizontal (180°) as needed. The hinged hoisting eye (a.k.a. universal eye) allows for the clamp to place and lift the load from any direction, or with a multiple leg sling without side-loading the clamp. Available in a variety of models:

- IPU10 - Standard clamp for materials with a surface hardness to 363HV10 (345 HB).
- IPU10J - Larger jaw opening.
- IPU10S - For use with Stainless Steel material.
- IPU10H - For use with materials with a surface hardness to 472HV10 (450 HB).

Features:

- Available in capacities of 0.5 thru 30 metric tons
- Higher Working Load Limits are available upon request.
- Wide variety of jaw openings available: 0 to 155 mm.
- Welded alloy steel body for strength and smaller size. Forged alloy components, where required.
- Individually Proof Tested to 2 times the Working Load Limit with certification.
- User manual and test certificate included with each clamp.
- Full 180° turning range for material transfer, turning or moving.
- Lock open, lock closed ability with latch for pretension on material and then release of material.
- For use with materials with surface hardness to 279HV10, only 5% min WLL is needed.
- Maintenance and repair kits are available.
- All sizes are RFID EQUIPPED.

... [Read more](#)

Material: Alloy Steel

Marking: According to standard, CE-marked, Logo, WLL, jaw capacity, serial number, proof load test date

Temperature range: -40°C up to +100°C

Standard: EN 13155

Vertical Lifting Clamp IPU10J

Blueprint

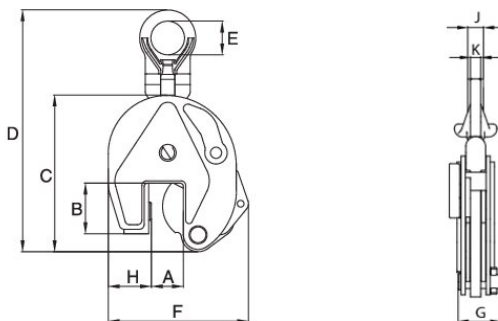

Technical data

Part code	Code	WLL ton	Jaw width mm	B mm	C mm	D, mm	E mm	F mm	G, mm	H, mm	K mm	J mm	Weight kg
502100050301650	0.5-IPU10J	0.5	15-30	45	128	209	40	128	42	32	11	-	1.9
502100100401650	1-IPU10J	1	20-40	55	151	221	40	141	42	41	11	-	2.5
502100300801650	3-IPU10J	3	40-80	115	270	432	75	277	78	67	20	-	17.3
502100450801650	4.5-IPU10J	4.5	40-80	126	302	515	80	336	84	95	20	44	18.9
502100601001650	6-IPU10J	6	50-100	115	270	432	75	281	82	72	20	-	26.5
502100901001650	9-IPU10J	9	50-100	126	325	550	80	360	94	105	20	44	34.2
502101201081650	12-IPU10J	12	54-108	178	438	662	80	491	121	136	25	41	65
502101601281650	16-IPU10J	16	64-128	208	521	784	88	562	121	160	25	45	85
502102251551650	22.5-IPU10J	22.5	80-155	255	628	938	110	660	139	196	25	49	149
502103001551650	30-IPU10J	30	80-155	255	628	942	110	660	153	196	30	54	166