

Sling Hook SHC POWERTEX (with clevis)

Product information



The POWERTEX Sling Hook with clevis is part of the Powertex G10 Lifting Sling Chain Components range. The sling hook is very easy to use and can be attached rapidly to lifting points. The hook has a solid latch.

Available for 6 mm up to 22 mm chain and from WLL 1.4t up to WLL 19t.

Also available as eye type (POWERTEX SH).

Powertex G10 Range benefits:

- 25% higher capacity compared to traditional Grade 8 components
- All POWERTEX G10 components are powder painted in luminous red
- Multi-functional master links and components are included in the range to allow quick and cost-effective assembly of chain slings
- The components meet EN 1677 part 1/2/3/4 +25% WLL
- Each forged component is crack detection tested, and samples are proof load tested.
- Each component is type tested in the factory and fatigue rated to 20,000 cycles at 1.5 times the WLL
- Full traceability through a batch number
- Replacement spare parts available
- All components are chromium 6 free
- POWERTEX 2.2 certificate enclosed with each box of components
- The components may also be used with Grade 8 chain to EN 818-2. In such a case, the chain sling needs to be rated as Grade 8 in accordance with EN 818-2 ... [Read more](#)

Marking: According to standard, POWERTEX + Model (SHC-6-10) + traceability code.

Temperature range: -40°C up to +200°C without reduction in WLL

Finish: Powder painted in luminous red

Standard: EN 1677-2 (+25% WLL), AS 3776

Safety factor: 4:1

Grade: 10

Sling Hook SHC POWERTEX (with clevis)

Blueprint

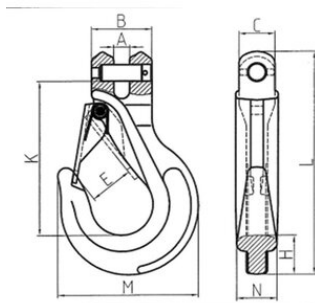

Technical data

Part code	Code	Chain diameter mm	WLL ton	A mm	B mm	C mm	E mm	H, mm	K mm	L mm	Mmm mm	Nmm mm	Weight kg
402300141450	SHC-6-10	6	1.4	8	28.8	18	23	19	79	112	66	15.5	0.3
402300251450	SHC-8-10	8	2.5	9	35	23	27	25	93.5	140	85	20	0.6
402300401450	SHC-10-10	10	4	12	44	25.5	33	28	121	174	103	24	1.2
402300671450	SHC-13-10	13	6.7	15	57	34	40	38	147.6	213.6	133	38	2.3
402301001450	SHC-16-10	16	10	18.5	67	41.5	44	41	166	250	161	41.5	3.8
402301601450	SHC-20-10	20	16	23	80	51	53	50	200	292	187	48	6.8
402301901450	SHC-22-10	22	19	25	97.5	61	72	63	228	339	240	57	10